



An Experimental Study of Conduction Heat Transfer Using Phase Change Material Ice Bag Gel in Bricks

Muhammad Khoirul Govari ^{1*}, Muhammad Iwan ², Doddy Irawan ³, Gunarto ⁴,
Fuazen ⁵, Dian fahrezi ⁶, fahrurrozi ⁷

^{1,2,3,4,5,6,7}, Mechanical Engineering, Universitas Muhammadiyah Pontianak, Pontianak,
Indonesia

201210026@unmuhpnk.ac.id ^{1*}, muhhammad.iwan@unmuhpnk.ac.id ²,
irawan.doddy@unmuhpnk.ac.id ³, gunarto@unmuhpnk.ac.id ⁴, fuadzen@unmuhpnk.ac.id ⁵,
201210039@unmuhpnk.ac.id ⁶, 201210010@unmuhpnk.ac.id ⁷

Address: Jl. Jenderal Ahmad Yani No.111, Bangka Belitung Laut, Kec. Pontianak Tenggara, Kota
Pontianak, Kalimantan Barat 78123

Email correspondence: 201210026@unmuhpnk.ac.id

Abstract This experiment investigates the heat transfer characteristics of an ice bag gel phase change material (PCM) incorporated within bricks. The study seeks to investigate the performance of ice bag gel as PCM in improving thermal behavior of building material. The experiment consisted of subjecting brick samples with and without ice bag gel PCM to thermal cycles in a semi-automated laboratory setup. The results indicate that ice bag gel PCM incorporated in bricks exhibited minimal changes and better heat transfer as compared to the dry bricks. It was observed that the ice bag gel PCM registered lower peak temperature and slower rates of temperature drop which means their heat storage and release characteristics were efficient. Furthermore, the ice bag gel system produced a steady radiation flux, indicating that it was able to minimize the effects of temperature variations. These results imply that ice bag gel PCM has the potential to be a green and economical option for enhancing thermal comfort and decrease energy consumption in buildings.

Keywords : PCM, Bricks, Temperature, Thermal, Ice Bag

1. INTRODUCTION

Anthocyanins are water-soluble pigments present in fruits, vegetables, flowers, and grains. These pigments belong to the flavonoid group and play an essential role in predetermining the color of the plant. It is noted that the element of popularity of these pigments is consistently maintained since anthocyanins are appealing to the public, performing numerous functions and actions. Anthocyanins are characterized by their 3° and 5° hydroxyl groups in their B-rings and their stability increases with the number of these groups. As a result of the discovery of anthocyanins content in grape pomaces, their usage became widespread in many countries of the world beyond Australia including China, Egypt, UK, Spain among others. This has resulted in instilling uncontrolled enthusiasm around polyphenolic based biopesticides, agri-fuels, anti-cancer agents and bright, high value pigments among others. Despite these widespread applications, there was a lack of data on the main active components in grape pomace which raise essential questions regarding their anticancer abilities. This drove the focus of numerous research outward, popularizing grape pomace and anthocyanins as a natural sources of various anticancer agents and many more applications. In crude extracts obtained from grape pomace as a

source considerably high contents of bioactive constituents, in other words, up to 600 mg/g of anthocyanins were determined in the extracellular extract.

The need to fill this knowledge gap is critical for maximizing properties of materials like thermal efficiency, phase change temperature, and strength in order to achieve practical use in reality based construction scenarios (Sharma et al., 2021). This experimental study seeks to determine the conduction heat transfer characteristics of ice bag gel PCM embedded bricks under semi-automatic laboratory conditions. The study explores the durability and performance of the composite system for it to advance energy efficient building design on a mass scale.

2. LITERATURE REVIEW

The using of phase change materials (PCMs) has been to improve the energy efficiency and thermal comfort of building construction materials. There are many latent heat that can be stored in PCMs as well as such that are capable of changing states which enable them to absorb and release thermal energy. This makes it easy to apply them in thermal energy storage (TES) projects. Among several studies, Cabeza et al. (2011) and Sharma et al. (2021) explain how beneficial these materials are incorporated in construction works especially in trying to reduce peak temperature loads when constructing buildings and in their energy use. This ability highlights their importance with the ever-increasing interest in sustainable building materials.

The combination of PCMs in bricks has been researched in great detail in relation to bricks thermal activities while focusing on their potential for enhancing indoor temperature stability. PCM-containing bricks were shown to reduce thermal conductivity and increase thermal inertia to building envelopes, as demonstrated by Alqallaf and Alawadhi (2017). Also, Saravanan and Prakash (2019) noted that reinforcement of PCMs into building materials promises benefits such as retaining energy, reduced reliance on HVAC systems, and improved indoor comfort conditions. Zhang et al. (2017) studied the long-term thermal performance of PCM-concrete bricks and concluded that heat penetration into buildings can be greatly minimized by incorporating PCM along with enhancing the thermal retention capacity of buildings.

Adhesion performed by water-based PCMs like ice bag gels contains appreciable latent heat values but their use in construction materials has not been fully realized. Water based PCMs have a unique thermal characteristic having high thermal conductivity and latent heat of fusion in them, hence enabling temperature self-regulation in extreme weather

(Lombardo et al., 2020). In the works of Rattore and Shukla (2019), the authors indicate that water-based PCMs are cheaper, safer and more ecological than the other types of PCMs. However, issues such as phase separation and subcooling still have to be addressed. As demonstrated in investigations of Farid et al. (2016) and Konuklu et al. (2015), these were overcome by use of new recipes such as gelling ice systems.

The optimization of the thermal performance of both the PCM brick and the brick matrix is defined by the material properties of these two components. For example, the work carried out by Tyagi et al. (2020) pointed out that the thermal conductivity and melting temperature of mastics have to be optimized for the heat load of the specific building. Soares et al. (2013) and Xu et al. (2019) went further with this, completing it with a description of encapsulation techniques and PCM dispersion into the brick matrix, which are equally important in reducing losses and destruction of the structure. Hence, these results raise the important issue of the ways to carry out the experimental determination of the dynamic thermal responses of the PCM-brick systems to changing environmental conditions.

Although PCMs hold great promise when applied as building materials, the understanding of their thermal and structural behaviour in time is still lacking. Newer research reports, such as those by Meng et al. (2022) and Jamil et al. (2020), recommend that the life-cycle evaluation of these bricks is taken into consideration. There is a need to address aspects such as durability, thermal cycling stability, and environmental impact. The objective of this research is to bring answers to these questions, focusing on the thermal behaviour of brick walls with ice bag gel PCM cores. Consequently, by using a new way of formulating and integrating the PCM, this study adds to the existing knowledge on sustainable and energy-efficient building materials.

3. METHODS

Materials used

a. Bricks : SNI standard sized blocks for testing.

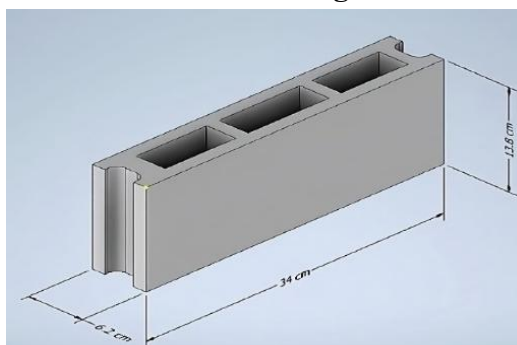

Figure 1. sketch Bricks

b. Phase change materials :

Ice bag (water-based PCM): is a gel medium that is capable of reducing and is used for storing at low temperatures, included in the category of passive thermal energy storage materials, Ice bags are known for their lower melting point, providing efficient thermal regulation at higher temperatures low. The propylene glycol material in the ice bag is biodegradable, easily decomposed so it is environmentally friendly, and is not toxic or poisonous, so it is suitable for use.



Figure 2. Ice Bag

Experiment Set Up

Planting PCM in Concrete Blocks: PCM capsules or reservoirs will be embedded in concrete blocks to avoid leaks and ensure safe handling in the concrete block hole before inserting the ice gal, the concrete block hole is coated with liquid cement so that the pores can be closed tightly, so that PCM can be locked inside concrete bricks. After that, open the soaked ice bag and pour the contents of the ice bag into the concrete bricks according to the ratio specified in each hole in the concrete brick



Figure 3. Bricks

a. Bricks that are inserted into Ice Bags

As a phase change material it will be more efficient in absorbing and releasing heat, so it can be used in various thermal applications. Apart from that, the Ice Bag also has good stability so that it can last for quite a long period of time. This is what makes the

Ice Bag and ideal choice in this research. By utilizing the good thermal insulation properties of the Ice Bag, it is hoped that it can make a significant contribution



Figure 4. Ice Bags in Bricks

b. Brick Structures



Figure 5. Brick Structures

c. Temperature Sensor

Temperature sensors will be installed inside and on the surface of the concrete block to measure temperature changes that occur in the concrete block.



Figure 6. Data Collection

d. Heating Cycle

Throughout the day, direct thermal cycles with sunlight will expose the blocks.



Figure 7. Research location in Pontianak

4. RESULTS

Table 1. Data Collection Temperature Difference Ice Bag and Non PCM

Time	Temperature Difference Ice Bag (K)	Temperature Difference Non PCM (K)
06:17:47 a.m.	0,00	0,00
07:20:10 a.m.	3,00	2,00
08:22:32 a.m.	7,00	5,00
09:24:55 a.m.	9,00	6,50
10:27:18 a.m.	11,00	10,75
11:29:41 a.m.	10,00	10,00
12:32:03 p.m.	5,50	3,50
01:34:26 p.m.	4,75	1,50
02:36:49 p.m.	4,50	1,75
03:39:12 p.m.	3,50	0,50
04:41:35 p.m.	2,25	1,50
05:43:58 p.m.	2,25	0,75

Table 2. Data Collection Heat Transfer Rate Ice Bag and Non PCM

Time	Heat Transfer Rate Ice Bag (Q)	Heat Transfer Rate Non PCM (Q)
06:17:47 a.m.	0,00	0,00
07:20:10 a.m.	0,31	0,28
08:22:32 a.m.	0,73	0,70
09:24:55 a.m.	0,93	0,91
10:27:18 a.m.	1,14	1,51
11:29:41 a.m.	1,04	1,40
12:32:03 p.m.	0,57	0,49
01:34:26 p.m.	0,49	0,21
02:36:49 p.m.	0,47	0,25
03:39:12 p.m.	0,36	0,07
04:41:35 p.m.	0,23	0,21
05:43:58 p.m.	0,23	0,11

Table 3. Data Collection Flux Radiation Ice Bag and Non PCM

Time	Flux Radiation Ice Bag	Flux Radiation Non PCM
06:17:47 a.m.	407,04	407,04
07:20:10 a.m.	479,95	475,41
08:22:32 a.m.	517,47	512,67
09:24:55 a.m.	562,26	555,45
10:27:18 a.m.	606,27	613,54
11:29:41 a.m.	622,72	632,01
12:32:03 p.m.	602,65	608,08
01:34:26 p.m.	599,06	606,27
02:36:49 p.m.	604,46	608,08
03:39:12 p.m.	577,82	586,60
04:41:35 p.m.	563,97	591,91
05:43:58 p.m.	542,01	567,41

Table 4. Data Collection Top Surface Ice Bag and Non PCM

Time	Top Surface Ice Bag	Top Surface Non PCM
06:17:47 a.m.	303,15	303,15
07:20:10 a.m.	315,90	315,15
08:22:32 a.m.	321,90	321,15
09:24:55 a.m.	328,65	327,65
10:27:18 a.m.	334,90	335,90
11:29:41 a.m.	337,15	338,40
12:32:03 p.m.	334,40	335,15
01:34:26 p.m.	333,90	334,90
02:36:49 p.m.	334,65	335,15
03:39:12 p.m.	330,90	332,15
04:41:35 p.m.	328,90	332,90
05:43:58 p.m.	325,65	329,40

DISCUSSION

Differences in temperature reduction in bricks with Ice Bag and Non PCM

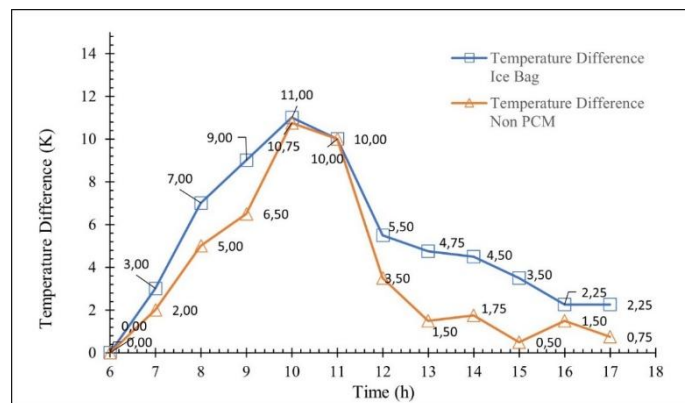
**Figure 8.** Temperature difference

The graph shows the temperature difference between Ice Bag (blue) and Non PCM (orange) versus time. At the beginning of the observation (6–8 hours), Non PCM had a lower temperature difference than Ice Bag, with a maximum value of 2 K at 7 hours, while Ice Bag reached 7 K at the same time. This shows that the Ice Bag is more effective at absorbing heat in the initial phase, possibly due to the phase change mechanism which requires more energy to melt. The peak temperature difference in the Ice Bag occurred at 10 o'clock with a value of 11 K, slightly higher than Non PCM which reached a peak of 10 K at almost the same time. After this peak, the Non-PCM temperature difference drops sharply, reaching 1.5 K at 13 hours and almost zero after 15 hours. In contrast, Ice Bag shows a more gradual decline, with the temperature difference still being around 4.5 K at 14 hours and remaining constant. above 2 K until 17 hours. This difference in pattern reflects the Ice Bag's ability to maintain cooling performance longer than Non PCM, which tends to quickly lose its capacity to absorb heat. The stability of Ice Bags can be attributed to the material's property of utilizing latent heat during phase changes, making it more suitable for applications that require stable and long-term cooling. On the other hand, Non PCM is more effective for applications that require fast heat absorption but in a short time. This consistent performance of the Ice Bag makes it a more efficient choice for temperature regulation over longer periods of time.

Heat transfer rate Ice Bag and Non PCM

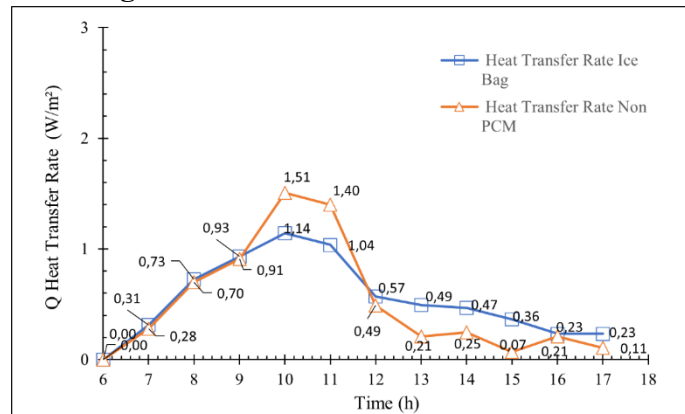

Figure 9. Heat transfer Rate

$$Q = K \cdot A \cdot \frac{\Delta t}{L} \quad (1)$$

Wherei Q is Heat Transfer Rate, K is Thermal Conductivity, A is Top Surface Area, ΔT is Temperature Difference, L is Brick Wall Thicknes

The graph represents the comparison of heat transfer rates Ice Bag (blue) and non-PCM (orange) for 14 hours. The highest value was recorded in the non-PCM situation during 10 hours, thus the peak was garner 1.51W, which is far low than , ice bag at a value of 1.14W. This indicates that non-PCM’s transfers heat faster than ice bag specifically in the beginning until the most of the middle observation. However, after 12 o clock the non-PCM value started to decline so much that by 16 hours it reached almost to nil. For ice bag on the other hand, heat transfer value was less and exhibited quite a stable value rather than decreasing sharply after its maximum. The reason for this is the ice bag model which is that the ice bags, uses heat absorption, thus allowing heat to be released more slowly & steadily, while non-PCM, which doesn’t absorb the heat, loses its energy quickly. So ice bags are more advantageous where heat sources are to be maintained rather than power sources. Non-PCM can be used where strong sources of heat are required.

Solar radiation waves in Watt/m² units

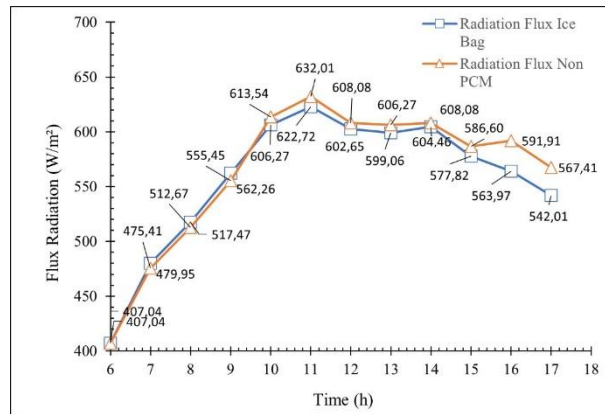

Figure 10. Flux radiation

$$\Phi = \epsilon \cdot \sigma \cdot T^4$$

(2)

Where Φ is Radiation Flux, ϵ is Emivisibility of Objects, σ is Constant Stefa-boltzman, T^4 is Objective Temperature

The time graph displays the radiation’s flux (W/m²) from Ice Bag (blue) and non-PCM (orange) with reference to time. For the most part, the radiation flux pattern of the two is almost similar, with a sudden peak towards the end of the observation at approximately between 9 and 10 o’clock. Ice Bag peaks at a flux of 622.72 W/m² while non-PCM recorded a high of 632.01 W/m² at the same period. Both of them begin receding after the peak ` however, their patterns are almost similar how ever ice bag declines more evenly and in a more controlled manner compared to non-PCM. For the subsequent hours the Ice Bag radiation flux still remained slightly below the non-PCM after which it recorded a starker

difference after around 16 hours. By the hour seventeen, Ice Bag radiation flux stood at 542.01 W/m² while non-PCM was at 567.41 W/m². Release of radiant energy by the Ice Bag is more restrained due to it having a regulated mechanism of latent heat release causing the drawn out decline.

On the other hand, non-PCM which has no phase change mechanism reaches the peak quicker but has a faster decline in the rate of heat release after its peak, which may be detrimental to its cooling suitability at later times. All in all, Ice Bags are able to maintain a less variable radiant flux and hence are more reliable for applications where thermal stability is needed, whereas non-PCM is appropriate for low energy release time applications.

Top temperature surface

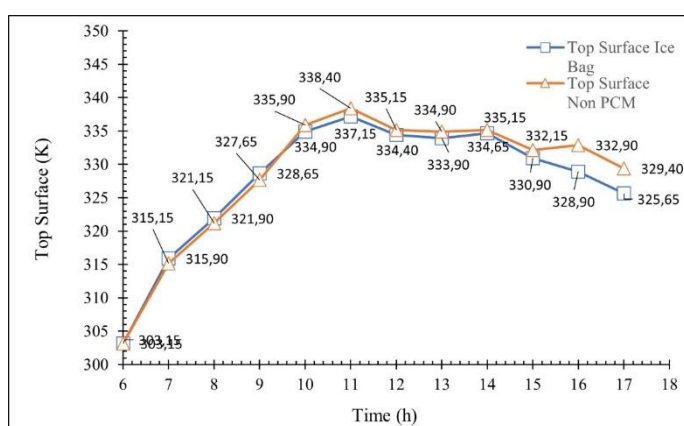

Figure 11. Top temperature surface

The chart depicts the time-dependent upper side temperature of the two tested systems, “Ice Bag” and “Non-PCM”. In general, it can be observed for both systems that there is a steady rise in temperature for the time period which is recorded early in the observation, around 6 o’clock up to the peak values at around 10 to 12 hours. For the Ice Bag system, the temperature is about 303.15K but it slowly rises to about 338.40 K before it starts to fall back down. However, the other non-PCM system has a similar trend in the beginning but it reaches 337.15 K a bit quicker then the temperature starts to fall. The temperature drop on the Ice Bag seems slower when compared with non-PCM. This is indicative of the fact that the Ice Bag has a superior performance in compressing the temperature for greater lengths. Thus it can be concluded that ice bags are superior than non-PCM in regard to temperature moderation and retention of thermal equilibrium. Furthermore the temperature dispersions in the non-PCM systems seem more sharper after reaching the peak, which indicates a lower level of thermal efficiency compared to Ice Bag.

CONCLUSION

This research examines the effectiveness of ice bag as a phase change material (PCM) to improve the thermal performance of bricks. The findings show that the integration of ice bag phase change material (PCM) in bricks significantly reduces temperature variations and increases heat transfer efficiency compared to bricks without Ice Bags. Ice Bag-enhanced bricks showed a lower peak temperature and a slower rate of temperature decline, reflecting their capacity to progressively absorb and release heat. which confirms its efficacy in thermal load management through heat storage and release during phase transitions. Consistent radiation flux from the Ice system

Ice bag highlights its capacity to manage temperature variations through effective energy storage and release. The surface temperature of Ice Bag mix bricks consistently remained lower during peak hours and showed a slower rate of decline, indicating its efficacy in maintaining a more comfortable indoor environment. These findings suggest that Ice Bag-enhanced bricks can serve as a cost-effective and sustainable approach to reduce energy consumption in buildings while increasing thermal comfort. Future investigations may examine the long-term performance, durability, and economic feasibility of this technology.

LIMITATION

The process of collecting data in the field often faces various challenges, such as unpredictable weather, temperature instability, sensor errors, and the influence of wind. Extreme weather can compromise measurement accuracy, while sudden changes in temperature often impact equipment performance and data quality. Apart from that, sensor errors caused by technical problems or less than optimal calibration are also significant obstacles. Strong winds can also affect the stability of measuring instruments, resulting in inconsistent data.

REFERENCES

- Alqallaf, H., & Alawadhi, E. M. (2017). Concrete bricks incorporating phase change materials for thermal energy storage. *Energy and Buildings*, *151*, 234–246. <https://doi.org/10.1016/j.enbuild.2017.06.032>
- Cabeza, L. F., Castell, A., Barreneche, C., de Gracia, A., & Fernández, A. I. (2011). Materials used as PCM in thermal energy storage in buildings: A review. *Renewable and Sustainable Energy Reviews*, *15*(3), 1675–1695. <https://doi.org/10.1016/j.rser.2010.11.018>

- Farid, M. M., Kong, W., & Chai, L. (2016). Phase change materials for energy storage: Properties and applications. *Energy Procedia*, 91, 201–212. <https://doi.org/10.1016/j.egypro.2016.06.111>
- Jamil, A., Ala'a, H., & Akhtar, M. (2020). Stability of PCMs in thermal storage applications. *Construction and Building Materials*, 238, 117695. <https://doi.org/10.1016/j.conbuildmat.2019.117695>
- Konuklu, Y., Ostry, M., Paksoy, H. O., & Charvat, P. (2015). Review on encapsulation techniques of phase change materials. *Renewable and Sustainable Energy Reviews*, 48, 79–88. <https://doi.org/10.1016/j.rser.2015.03.013>
- Lombardo, M., Gennaro, R., & Polonara, F. (2020). Phase change materials and their applications in buildings. *Sustainability*, 12(22), 9571. <https://doi.org/10.3390/su12229571>
- Meng, X., Huang, Y., & Chen, C. (2022). Long-term thermal performance of PCM-based building materials. *Energy and Buildings*, 255, 111633. <https://doi.org/10.1016/j.enbuild.2022.111633>
- Rathore, P. K. S., & Shukla, S. K. (2019). Development of phase change materials for building applications: A review. *Renewable and Sustainable Energy Reviews*, 113, 109241. <https://doi.org/10.1016/j.rser.2019.109241>
- Saravanan, A., & Prakash, K. S. (2019). A comprehensive review on phase change material embedded bricks for energy conservation in buildings. *Materials Today: Proceedings*, 22, 1429–1436. <https://doi.org/10.1016/j.matpr.2020.10.010>
- Sharma, A., Tyagi, V. V., Chen, C. R., & Buddhi, D. (2021). Review on thermal energy storage with phase change materials and applications. *Renewable and Sustainable Energy Reviews*, 13(2), 318–345. <https://doi.org/10.1016/j.rser.2007.10.005>
- Soares, N., Costa, J. J., Gaspar, A. R., & Santos, P. (2013). Review of PCMs for building thermal energy storage. *Energy and Buildings*, 59, 82–103. <https://doi.org/10.1016/j.enbuild.2012.12.042>
- Tyagi, V. V., Kaushik, S. C., & Tyagi, S. K. (2020). Development in PCM technologies for building energy storage. *Energy and Buildings*, 121, 77–86. <https://doi.org/10.1016/j.enbuild.2020.10.034>
- Xu, X., Zhang, Y., & Li, X. (2019). Phase change material-integrated construction materials: Thermal and structural analysis. *Building and Environment*, 152, 1–14. <https://doi.org/10.1016/j.buildenv.2019.02.011>
- Zhang, Y., Lin, K., & Yang, R. (2017). Analysis of PCM-concrete bricks for building applications. *Building and Environment*, 98, 128–137. <https://doi.org/10.1016/j.buildenv.2015.12.013>